

PRODUCT SHEET

40-KW_e, SKID-MOUNTED, LOW-TEMPERATURE ORGANIC RANKINE CYCLE (LT-ORC) ENERGY PRODUCTION MODULE

ZE-40-ULH



Via della Consortia 2
37127 Verona - Italy
Tel +39 045 8378 570
Fax +39 045 8378 574
www.zuccatoenergia.it
info@zuccatoenergia.it

PLANT TECHNOLOGY

The structure of the proposed plant is based on the so-called low-temperature organic Rankine cycle (LT-ORC), and may be summed up by the diagram in Figure 1.

A heat source [1] generates heat, which is conveyed through a **vector fluid** circulating into a closed loop to one or more primary heat exchangers, usually a **preheater** and an **evaporator** [2], where said heat is transferred from the vector fluid to the **working fluid**.

The working fluid - a low-boiling, biodegradable, non toxic liquid when at room temperature - **boils** in the evaporator at a temperature far lower than that of water, becoming a high-pressure dry gas which spins through its expansion the impeller of a specifically designed and sized **turbine** [3].

The high-speed rotation (12.000÷18.000 Rpm) of the turbine shaft spins the rotor of a **generator** which is directly connected to it, thus producing **electric power** [4] which, after being synchronized in frequency, phase and voltage by a **power converter**, may be injected into the national power grid or self-consumed, according to local needs and policies.

Downstream the turbine, the working fluid - still in gas phase - is conveyed to another heat exchanger, called a **condenser** (5), where it is cooled, releasing its excess heat and condensing back into a liquid which is collected in a **condensation tank**, ready to be sent back to the primary heat exchanger by a **recirculation pump**, thus closing the loop.

Excess heat released in the condenser is a low-temperature thermal energy source itself, which may be **used for other purposes** such as preheating or desiccating biomass fuel (thus increasing its heating value), building heating, hot water production and so on.

In case that is not possible, residual heat may be dissipated by using an **external cooling system** [6] such as an evaporative cooling tower or a dry cooler.

IN SHORT

Low-Temperature Organic Rankine Cycle (LT-ORC) Technology

Emission-free closed loop operation

A low-boiling-point working fluid is evaporated and expanded by heat

Working fluid expansion spins an high-speed turbine

The spinning turbine drives directly a generator

The working fluid is cooled down, condenses back into a liquid and is pumped back into the loop

Figure 1 - Plant diagram

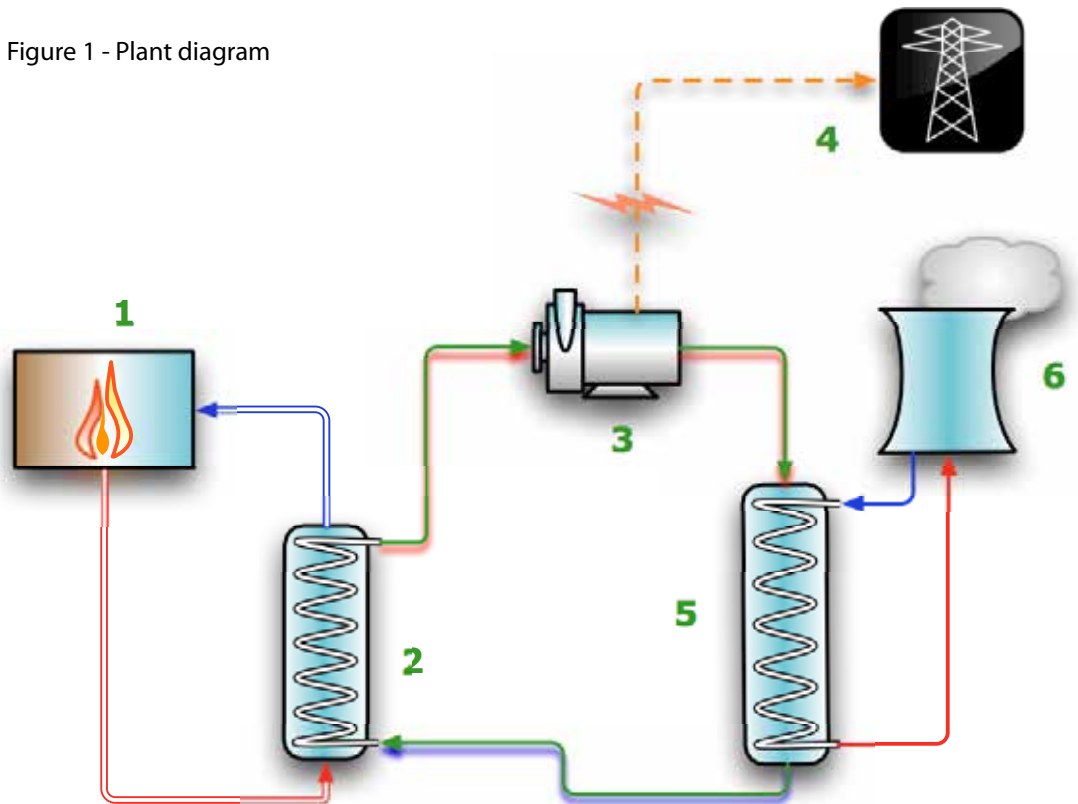

HIGH-PERFORMANCE

Independently designed and manufactured using the most advanced technologies in finite elements and fluid-dynamics analysis (CFD/CFX), ZE turbogenerators are designed from scratch to operate in a low-temperature organic Rankine cycle which uses a special working fluid that offers better performances and several advances over traditional steam turbines:

- **Low operational temperature** which allow our systems to tap even low-grade heat sources;
- **High condensation temperature** which may allow the use of simple air-cooled condensers;
- **Totally dry working fluid**, which means no turbine blade erosion, giving the system **high reliability** and **reduced maintenance costs** as well as **fewer controls**;
- **Lower operational pressures** (20 bar max), which mean safer operation, less bureaucratic problems and reduced plant costs;
- **No atmospheric emissions** (closed circuit operation);

ENVIRONMENT-FRIENDLY

From an environmental standpoint, ZE systems are reproachless:

- **They recover otherwise wasted resources** such as waste heat and byproducts or help tapping renewable sources such as solar and geothermal heat;
- **They use plain tap water for thermal energy transfer** instead of environmentally-dangerous diathermal oil;
- **Their working fluid** is ozone-friendly, non-toxic, non flammable in liquid form, and 100% biodegradable;
- **They are made of recyclable, environmental friendly materials**, use a minimum of plastic parts and employ no toxic substances in their construction.

INNOVATIVE SOLUTIONS

The ZE turbogenerators have been **custom designed from scratch** for the purpose of being installed in small plants (<1MWe). So, several engineering solutions have been incorporated in their design to enhance their performance:

- **Direct turbine-to-alternator coupling**, to eliminate the attrition losses inherent in gearboxes;
- **Use of ceramic bearings** to prolong operational life and allow very high-rpm operation;
- **Custom-designed and sized turbines and power converters** for every plant size to obtain optimal mechanical-to electric energy conversion and performance in energy grid output.

Our innovative technology has already been **widely field-tested with success** in dozens of plants throughout Europe, Asia, Africa and America, from biomass and biogas fueled plants in Italy to solar-assisted plants in Africa, from large farms in the USA to Korean power stations..

All systems by Zuccato Energia are equipped with **telecontrol and telediagnostic systems** that allow constant monitoring and real-time intervention in case of malfunction through the 3G / GPRS / EDGE cellphone network and any Web-savvy device (PC or tablet).



IN SHORT

May be used to tap "low-grade" heat sources

Simpler plants

No turbine blade erosion

Lower pressure, higher safety

No atmospheric emissions

High reliability

State-of-the-art technology

Automated, operatorless systems

Remotely monitorable and controllable

FIELD-TESTED TECHNOLOGY

Zuccato Energia ORC systems have been in use for years in several installations : the following photos show some of them.

IN SHORT

Widely tested technology

Dozens of systems already in operation

Some systems operating non-stop since 2012 (except for scheduled maintenance)

Primary energy production from biomass-fueled boilers

Heat recovery from gases and cooling jackets for efficiency upgrade of gensets

Heat recovery from industrial processes

Solar heat plants

Geothermal plants



Sommalombardo (VA, Italy) - Power generation from biomass-fueled boiler (sawmill residues)



Heuksan (South Korea) - Heat recovery from thermoelectric power station (heavy oil gensets)



Città della Pieve (PG, Italy) - Power generation from biomass-fueled boiler (pruning residues)



Mestre (VE, Italy) - Heat recovery from biomass-fueled boilers and hot-air turbines



Rovato (BS, Italy) - Power generation from biomass-fueled boiler (end-of-life pallets)



Benneckstein (Germany) - Heat recovery from jackets and fumes of biogas-fueled gensets



Castrovillari (CS, Italy) Power generation from biomass-fueled boiler (pruning residues)



Borgoforte (MN, Italy) - Heat recovery from jackets and fumes of biogas-fueled gensets

For a more up-to-date and exhaustive list of our references, please consult the "References" section of our website, www.zuccatoenergia.it.

ORC CIRCUIT COMPONENTS

The ZE-40-ULH power generation module operates on a closed cycle and is made of various components, shown in the following diagram.

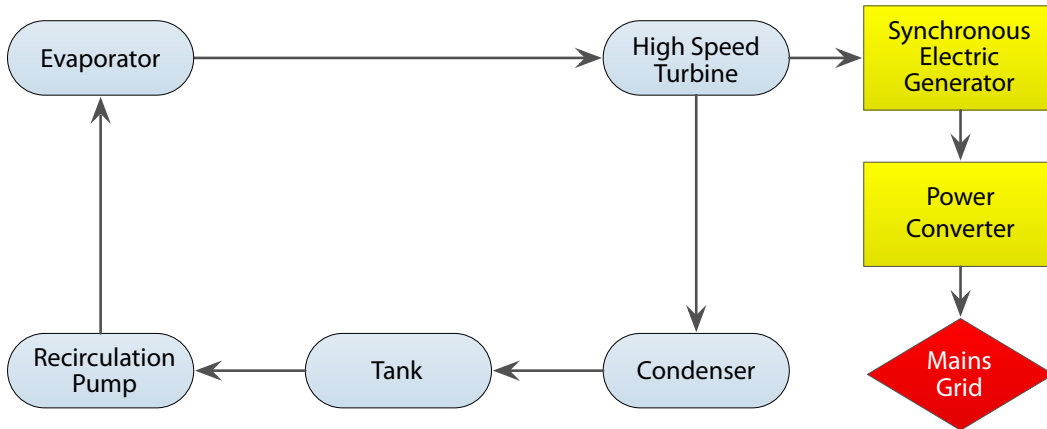

- **Evaporator:** in this heat exchanger, the heat of the vector fluid feeding the ORC module vaporizes the working fluid changing its state from liquid to gas, so increasing its pressure;
- **Turbine:** propelled by working fluid expansion, it has an ultralight impeller that reaches very high rotational speed (12-18.000 rpm) drawing along the generator rotor assembly;
- **Synchronous Electric Generator:** spinning at high speed thanks to its direct connection with the turbine, it produces electric power.
- **Inverter:** Ensures generator output meets all specifications (phase, frequency and voltage) to interface with the national power grid;
- **Condenser:** reduces the temperature of the working fluid gas downstream of the turbine, to make it go back to its ordinary liquid state;
- **Storage tank** to keep the condensed working fluid in liquid form;
- **Recirculation pump** to pump the fluid back in the ORC loop;

PROCESS DATA

These are the estimated process data for the plant:

EVAPORATOR	
Total thermal power input	450 kW _T
Vector fluid	Hot water
Vector fluid temperature (input / output)	≥ 94 °C / 86°C
Vector fluid flow rate	13.40 kg/s
Electric power output from turbine	40 kW _E

CONDENSER	
Thermal power dissipation	390 kW _T
Condenser cooling water temperature (in/out)	26°C / 31°C
Condenser circuit flow	18.65 kg/s

VECTOR FLUID

Vector fluid is the fluid that is used to convey heat from the heat source to the ORC module where its heat is used to evaporate the **working** fluid described in the next page.

The two fluids operate in separate loops and never mix - **only heat is transferred** between them.

Zuccato Energia has chosen to use **plain tap water** as a vector fluid instead of diathermal oil which, while maybe slightly more efficient at heat transfer, is far more dangerous to use, as it is flammable and potentially polluting if spilled.

In this plant, the vector fluid is plain **hot water** at 94 °C.

IN SHORT

Simple, straightforward design

High-efficiency components

Safe, eco-friendly vector fluid (overheated water)

IN SHORT

Exclusive working fluid

Low boiling point, high condensation point

Closed circuit = no contamination

No turbine blade erosion

Safe for man and environment

Custom designed low-temperature, high-speed radial turbine

Built-in alternator, mounted directly on the turbine shaft

Custom-designed, integrated inverter

WORKING FLUID

The high-performance **organic working fluid** is the key component that allowed Zuccato Energia to create its ORC plants, granting optimal performances due to its excellent specifications:

- **Wide operating temperature range** that allows tapping into low-quality heat sources that were previously considered as unexploitable;
- **High condensing temperature** allowing the use of standard cooling towers;
- **Totally dryness** when in gas form, so no cavitation and no turbine blade erosion;
- **Low operational pressures** granting better safety, less bureaucratic problems, lower costs;
- **Totally ozone-friendly**, non toxic, 100% biodegradable and non-flammable in liquid form, so it is environment-friendly and any accidental leaks are neither harmful or dangerous;
- **Closed-loop operation** means almost no need for refills, no steam nor water consumption and no emissions, so plants can be cheaper to operate, simpler and more compact than equivalent steam-based ones.

The fluid inside the plant undergoes several phase changes and treatments; the process specifications are resumed in the following table:

WORKING FLUID	
Type	Mixture of non-toxic, non-flammable, environment-friendly HFCs
Operational range	60-165°C
Condensation temperature	~33°C @ 1 bar
Working pressure	max. 20 bar
Organic vapor mass flow	~ 2.65 Kg/s

TURBINE, GENERATOR AND INVERTER

The following tables show the main technical specification of the turbine inside the ZE-300-ULH+ power generation module and its attached generator and inverter

TURBINE	
Type	Single-stage radial inflow turbine w/fixed nozzles, directly coupled to the generator shaft
Operating Temperature (Input/Output)	85°C in / ~ 60°C out
Stage pressure	PS 4.42 (tested to 10 bar)
Materials	Machined steel (body) / Aluminium alloy (impeller)
Speed control	Feedback loop on the generator current output
Seals and gaskets	Sealed labyrinth on impeller back and optionally at generator interface. Environmental seal : gaskets and O-rings

GENERATOR	
Type	Synchronous, permanent magnet
Power Output	40 kW _E
Rotational Speed	13.000 Rpm (12...18 kRpm)
Rectifier /synchronizer	Built-in / Included
Cooling system	Water jacket
Cooling fluid	Water + glycol mix @ T _{IN} <40°C

INVERTER	
Type	IGBT- mains synchronized, air-cooled
Output power	40 kW _E
Output voltage / frequency	from 380 to 480 V 3-phase, 50/60Hz
Max operational environmental temperature	40°C
Braking chopper	included, 40 kW

SYSTEM COMPONENTS

HEAT EXCHANGERS

The **heat exchangers** used in this power generation module are of the brazed plate type - the most compact and efficient solution for several applications. They are made by brazing several quality corrugated steel plates together, taking care first to turn the fishbone-shaped corrugations on each plate 180° from the adjacent plate. Keeping in mind that the fluid-passing sections are very small, the heat exchange-to-encumbrance ratio of these exchangers is great. Among the characteristics for this type of exchanger, these are the most important ones:

- **Small size** : they occupy up to 10% of the space other exchanger types require, making transport easier and the plant smaller.
- **Low temperature differentials**: they can work with minimal temperature differences between cooling fluid and cooled fluid, thus increasing overall system efficiency;
- **Low load losses**: in most cases, even lower than those of a coaxial exchanger.
- **Resistance to dirt and corrosion**: high fluid turbulence and total use of the available surface means a drastic reduction in deposits due to material contained in the fluids. What's more, they may be perfectly cleaned using normal detergent fluids. Corrosion problems are avoided by using specifically resistant materials in their construction.

HEAT EXCHANGERS	
Type	Brazed plate
Operating pressures	30 bar (Nominal) / 39 bar (Test) /225 bar (Burst)
Construction materials	AISI316 S/S & 99,9% copper
Max working temperature	195°C

CONDENSATION TANK

Required to keep an adequate reserve of liquid working fluid for the plant, it is made of rust-proofed carbon steel with PN16 connections, has a capacity of **90 litres** and is equipped with a **built-in level sensor**.

WORKING FLUID PUMP

Required to make the condensed working fluid flow back into the ORC loop, its motor is of the closed short-circuited cage type with external ventilation . **Energy-efficient** (class I), it has **IP55 protection** and is certified to the **EN 60034-1 standard**. Equipped with **class F insulation** (Tmax=155°C), its hydraulic part is kept in place between the upper cap and the pump body by tie rods.

CONTROL PANEL

The control panel, hosted in an off-skid cabinet, hosts all **control, supervision, automation and communication electronics** for the power generation module. Equipped with a **touch-screen local control panel** as well as a **remote control interface**, it contains all **process management electronics**, including **temperature and pressure control** electronics and **alarm management systems**. The control panel also include a built-in **cellular modem router** that allows password-protected, policy-regulated remote access and system control through the Internet..

INVERTER and POWER DUMP SYSTEM

An on-skid cabinet hosts the **inverter circuitry** that conditions the generated power, modifying its phase, frequency and voltage to exacting requirements before sending it to the **mains interface panel** with low-voltage protection circuitry. The same cabinet host the **resistor banks** where the inverter **dumps and dissipates as heat** all the power generated as the turbine spins down during emergency stops, given that - due to safety considerations - in that situation the skid is totally cut off from the mains.

IN SHORT

Compact & efficient brazed plate heat exchangers

Ample reservoir of working fluid

High-efficiency recirculation pump

Fully automated control system

No human presence required

Touch-screen synoptic control panel

Remote control via mobile internet interface

Inverter and mains interface panels included

ZE-40-ULH SKID DIMENSIONS

IN SHORT

Standard version mounted on open skid for indoor installation

Skid dimensions: 3.3 x 1.4 x h 2.1 m

Ideal Installation area required: 6.3 x 4.4 x 3.6 m

Dry Weight : ~ 3100 Kg

Paneled version available

Containerized, weatherproof version for outdoor installation available

Custom skid designs available upon request

The ORC module is supplied mounted on a **self-supporting frame** ("skid") hosting all module components, ready to be connected to heat source and heatsink. Where necessary, this skid is capable of fitting inside a standard 20" container for shipping. Skid weight and dimensions are listed on the left and below.

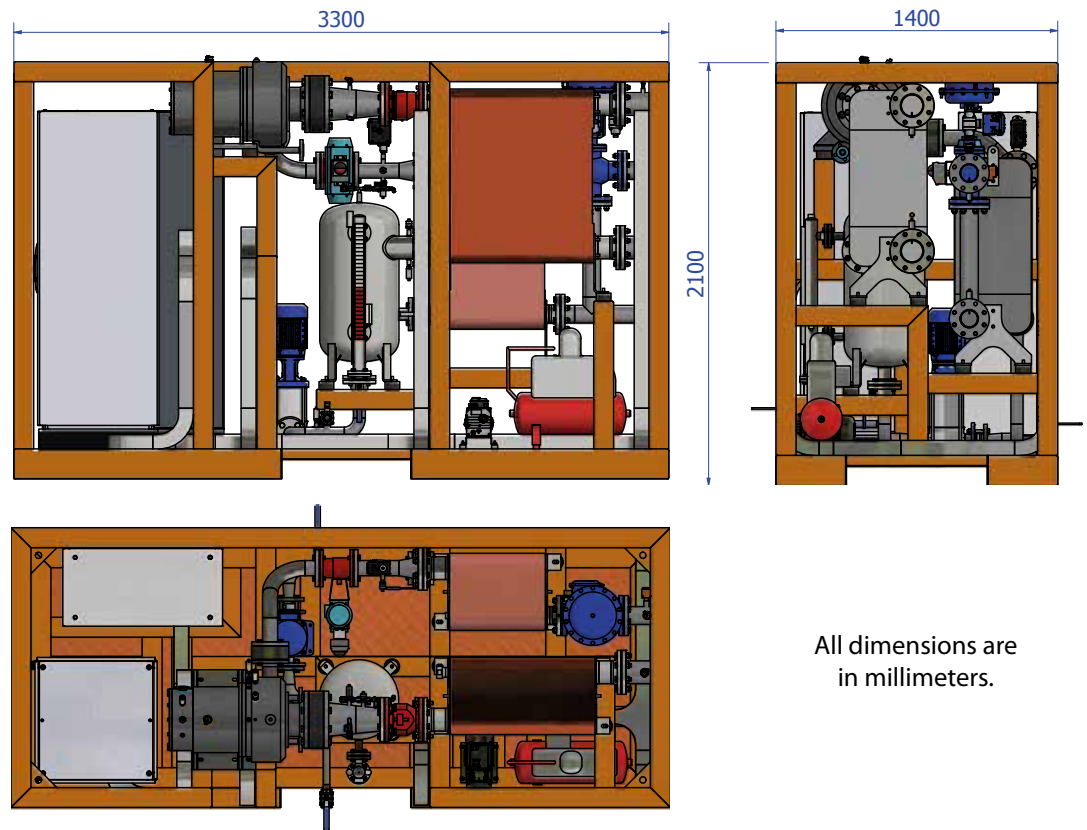

All dimensions are in millimeters.

Please keep in mind that the skid **ideally requires at least 1.5 meters of free space on all sides** for easy maintenance access.

Zuccato Energia, as system developer and manufacturer, may also upon request design and build the module with custom dimensions and working points, to tailor the system to the client's needs.

ZUCCATO ENERGIA CONTACTS

Legal & Operative Seat: Via della Consortia,2 - 37127 Verona (Italia)

Phone : +39 045 8378 570 - **Telefax:** +39 045 8378 574

E-Mail: info@zuccatoenergia.it - **Website :** <http://www.zuccatoenergia.it>

Office Hours: Monday to Friday, 8:30 to 12:30 and 14:30 to 18:30 CET (UTC+1)

ALL OUR BEST EFFORTS HAVE BEEN MADE TO ENSURE THAT THE DATA CONTAINED IN THIS DOCUMENTS ARE CORRECT AND UP TO DATE.

NOTWITHSTANDING THAT, THEY ARE TO BE CONSIDERED PURELY INDICATIVE, NOT CONTRACTUALLY BINDING AND SUBJECT TO CHANGE WITHOUT NOTICE .

© 2019 ZUCCATO ENERGIA SRL
ALL RIGHTS RESERVED

DOCUMENT IDENTIFIER :
ZE SK 040 ULH 190322 EN

