

TECHNICAL ATTACHMENT



PRODUCT SHEET 561-KWe, SKID-MOUNTED, LOW TEMPERATURE ORGANIC RANKINE CYCLE (LT-ORC) POWER GENERATION MODULE

ZE-500-LT



VIA DELLA CONSORTIA 2
37127 VERONA - ITALY
TEL +39 045 8378 570
FAX +39 045 8378 574
WWW.ZUCCATOENERGIA.IT
INFO@ZUCCATOENERGIA.IT

PLANT TECHNOLOGY

The structure of the proposed plant is based on the so-called low-temperature organic Rankine cycle (LT-ORC), and may be summed up by the diagram in Figure 1.

A heat source [1] generates heat, which is conveyed through a **vector fluid** circulating into a closed loop to one or more primary heat exchangers, usually a **preheater** and an **evaporator** [2], where said heat is transferred from the vector fluid to the **working fluid**.

The working fluid - a low-boiling, biodegradable, non toxic liquid when at room temperature - **boils** in the evaporator at a temperature far lower than that of water, becoming a high-pressure dry gas which spins through its expansion the impeller of a specifically designed and sized **turbine** [3].

The high-speed rotation (12.000÷18.000 Rpm) of the turbine shaft spins the rotor of a **generator** which is directly connected to it, thus producing **electric power** [4] which, after being synchronized in frequency, phase and voltage by a **power converter**, may be injected into the national power grid or self-consumed, according to local needs and policies.

Downstream the turbine, the working fluid - still in gas phase - is conveyed to another heat exchanger, called a **condenser** (5), where it is cooled, releasing its excess heat and condensing back into a liquid which is collected in a **condensation tank**, ready to be sent back to the primary heat exchanger by a **recirculation pump**, thus closing the loop.

Excess heat released in the condenser is a low-temperature thermal energy source itself, which may be **used for other purposes** such as preheating or desiccating biomass fuel (thus increasing its heating value), building heating, hot water production and so on.

In case that is not possible, residual heat may be dissipated by using an **external cooling system** [6] such as an evaporative cooling tower or a dry cooler.

Figure 1 - Plant diagram

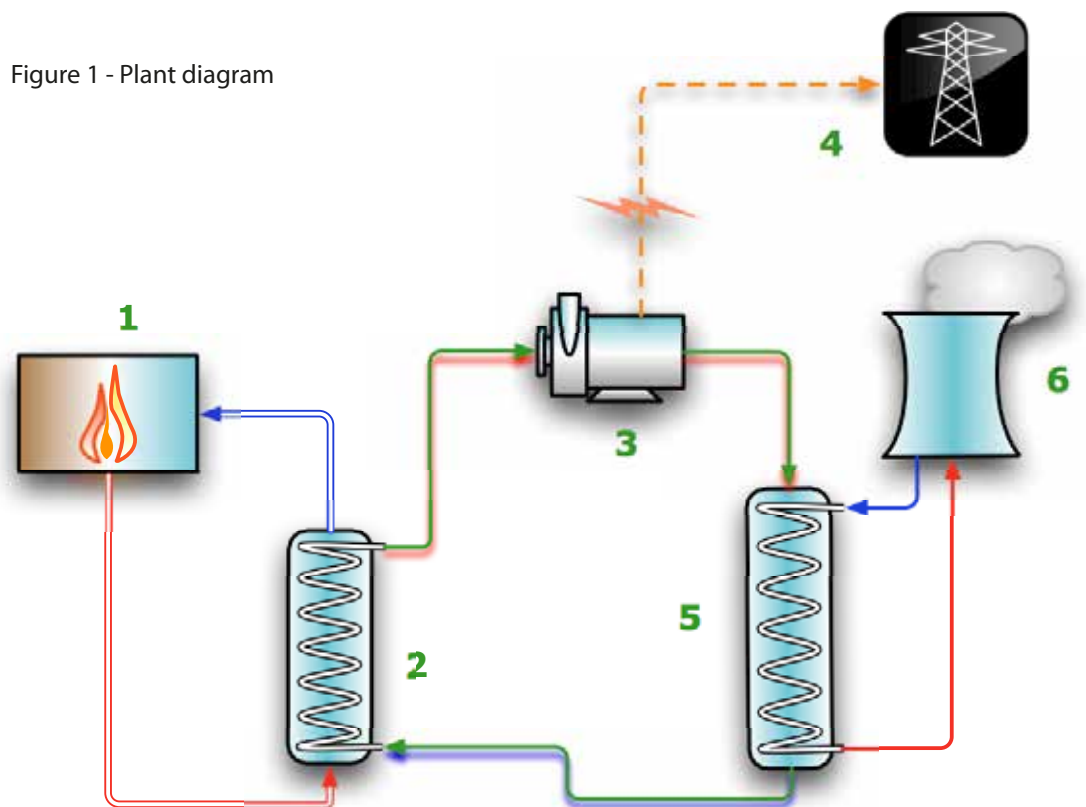

HIGH POWER, HIGH EFFICIENCY

The ZE-500-LT is the **largest power generation module** offered by Zuccato Energia, designed to operate in conjunction with boilers in **power generation applications** but equally well suitable for **industrial heat recovery systems** where large enough quantities of medium-temperature ($\geq 160^{\circ}\text{C}$) waste heat are available. If required, this modular unit is also capable to be **coupled with other similar or smaller units** to take advantage of all available thermal power.

The use of **shell-and tube heat exchangers** for the cold side instead of the usual brazed plate units gives the system the highest efficiency (16%) of all the Zuccato Energia range of products.

IN SHORT

Low-Temperature Organic Rankine Cycle (LT-ORC) Technology

Emission-free closed loop operation

A vector fluid conveys heat from the heat source to the ORC module

The conveyed heat evaporates a low-boiling-point working fluid which boils over into gas phase and expands

Working fluid expansion spins an high-speed turbine

The spinning turbine drives directly a generator

The working fluid is cooled down, condenses back into a liquid and is pumped back into the loop

HIGH-PERFORMANCE

Independently designed and manufactured using the most advanced technologies in finite elements and fluid-dynamics analysis (CFD/CFX), the ZE turbogenerators are designed from scratch to operate in a low-temperature organic Rankine cycle which uses a special working fluid that offers better performances and several advances over traditional steam turbines:

- **Low operational temperature** which allow our systems to tap even low-grade heat sources;
- **High condensation temperature** which may allow the use of simple air-cooled condensers;
- **Totally dry working fluid**, which means no turbine blade erosion, giving the system **high reliability** and **reduced maintenance costs** as well as **fewer controls**;
- **Lower operational pressures** (20 bar max), which mean safer operation, less bureaucratic problems and reduced plant costs;
- **No atmospheric emissions** (closed circuit operation);

ENVIRONMENT-FRIENDLY

From an environmental standpoint, ZE systems are reproachless:

- **They recover otherwise wasted resources** such as waste heat and byproducts or help tapping renewable sources such as solar and geothermal heat;
- **They use plain tap water for thermal energy transfer** instead of environmentally-dangerous diathermal oil;
- **Their working fluid** is ozone-friendly, non-toxic, non flammable in liquid form, and 100% biodegradable;
- **They are made of recyclable, environmental friendly materials**, use a minimum of plastic parts and employ no toxic substances in their construction.

INNOVATIVELY DESIGNED

The ZE turbogenerators have been **custom designed from scratch** for the purpose of being installed in small plants (<1MWe). So, several engineering solutions have been incorporated in their design to enhance their performance:

- **Direct turbine-to-alternator coupling**, to eliminate the attrition losses inherent in gearboxes;
- **Use of ceramic bearings** to prolong operational life and allow very high-rpm operation;
- **Custom-designed and sized turbines and power converters** for every plant size to obtain optimal mechanical-to electric energy conversion and performance in energy grid output.

Our innovative technology has already been **widely field-tested with success** in dozens of plants throughout Europe, Asia, Africa and America, from biomass and biogas fueled plants in Italy to solar-assisted plants in Africa, from large farms in the USA to Korean power stations..

All systems by Zuccato Energia are equipped with **telecontrol and telediagnostic systems** that allow constant monitoring and real-time intervention in case of malfunction through the 3G / GPRS / EDGE cellphone network and any Web-savvy device (PC or tablet).



IN SHORT

May be used to tap "low-grade" heat sources

Simpler plants

No turbine blade erosion

Lower pressure, higher safety

No atmospheric emissions

High reliability

State-of-the-art technology

Automated, operatorless systems

Remotely monitorable and controllable

FIELD-TESTED TECHNOLOGY

Zuccato Energia ORC systems have been in use for years in several installations : the following photos show some of them.

IN SHORT

Widely tested technology

Dozens of installations already in operation

Some plants have been operating non-stop since 2012 (except scheduled maintenance)

Primary energy production from biomass-fueled boilers

Heat recovery from exhaust gases and cooling jackets

Heat recovery from engines, gasifiers, turbines



Sommalombardo (VA, Italy) - Power generation from biomass-fueled boiler (sawmill residues)



Heuksan (South Korea) - Heat recovery from thermoelectric power station (heavy oil gensets)



Città della Pieve (PG, Italy) - Power generation from biomass-fueled boiler (pruning residues)



Mestre (VE, Italy) - Heat recovery from biomass-fueled boilers and hot-air turbines



Rovato (BS, Italy) - Power generation from biomass-fueled boiler (end-of-life pallets)



Benneckestein (Germany) - Heat recovery from jackets and fumes of biogas-fueled gensets



Castrovillari (CS, Italy) Power generation from biomass-fueled boiler (pruning residues)



Borgoforte (MN, Italy) - Heat recovery from jackets and fumes of biogas-fueled gensets

For a more up-to-date and exhaustive list of our references, please consult the "References" section of our website, www.zuccatoenergia.it.

ORC CIRCUIT COMPONENTS

Besides the aforementioned working fluid, the power generation module is made of various elements, shown in the following diagram.

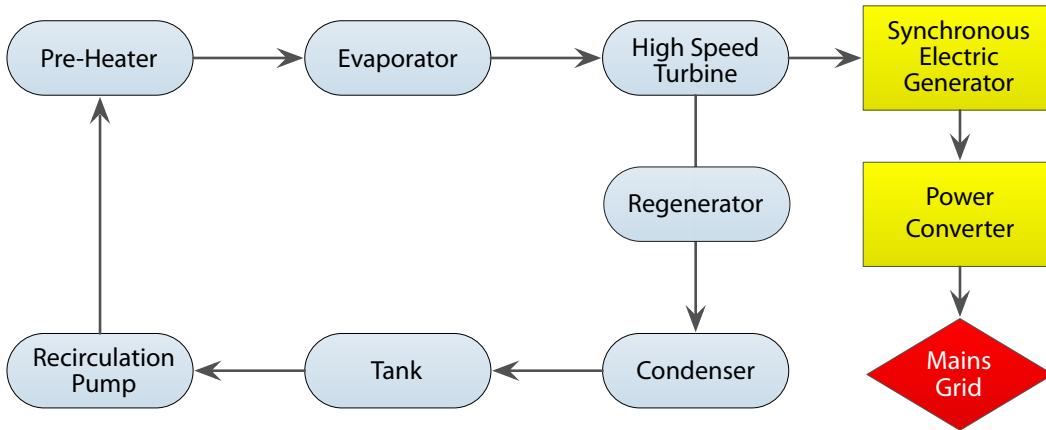

- **Pre-Heater:** in this heat exchanger, the heat from the heat source, conveyed to the ORC module by the vector fluid, preheats the working fluid;
- **Evaporator:** in this heat exchanger, the heat of the vector fluid feeding the ORC module vaporizes the working fluid changing its state from liquid to gas, so increasing its pressure;
- **Turbine:** propelled by working fluid expansion, it has an ultralight impeller that reaches very high rotational speed (12-18.000 rpm) drawing along the generator rotor assembly;
- **Synchronous Electric Generator:** spinning at high speed thanks to its direct connection with the turbine, it produces electric power.
- **Inverter:** Ensures generator output meets all specifications (phase, frequency and voltage) to interface with the national power grid;
- **Regenerator:** pre-preheats the incoming working fluid using the heat from the working fluid itself downstream of the turbine, to increase system efficiency;
- **Condenser:** reduces the temperature of the working fluid gas downstream of the turbine, to make it go back to its original liquid state;
- **Storage tank** to keep the condensed working fluid in liquid form;
- **Recirculation pump** to pump the fluid back in the ORC loop;

PROCESS DATA

These are the estimated process data for the plant:

PREHEATER + EVAPORATOR	
Total thermal power input	3 500 kW _T
Vector fluid temperature (input / output)	≥ 160 °C / 145°C
Vector fluid flow rate	54.03 kg/s

CONDENSER	
Thermal power dissipation	2 909 kW _T
Condenser cooling water temperature (in/out)	28°C / 38°C
Condenser circuit flow	69.41 kg/s

VECTOR FLUID

Vector fluid is the fluid that is used to convey heat from the heat source to the ORC module where its heat is used to evaporate the **working** fluid described in the next page.

The two fluids operate in separate loops and never mix - **only heat is transferred** between them. Zuccato Energia has chosen to use **plain tap water** as a vector fluid instead of diathermal oil which, while maybe slightly more efficient at heat transfer, is far more dangerous to use, as it is flammable and potentially polluting if spilled.

In this plant, the vector fluid is **overheated water** at 160°C - i.e. water heated above the boiling point but kept liquid under pressure.

IN SHORT

Simple, straightforward design

High-efficiency components

Safe, eco-friendly vector fluid (overheated water)

IN SHORT

Exclusive working fluid

Low boiling point, high condensation point

Closed circuit = no contamination

No turbine blade erosion

Safe for man and environment

Custom designed low-temperature, high-speed radial turbine

Built-in alternator, mounted directly on the turbine shaft

Custom-designed, integrated inverters

WORKING FLUID

The high-performance organic working fluid is the key component that allowed Zuccato Energia to create his ORC plant, thanks to its excellent technical specifications, such as:

- **Wide operating temperature range** that allows tapping into low-quality heat sources that were previously considered as unexploitable;
- **High condensing temperature** allowing the use of standard cooling towers;
- **Totally dryness** when in gas form, so no cavitation and no turbine blade erosion;
- **Low operational pressures** grant better safety, less bureaucratic problems, lower costs;
- **Total ozone-friendliness**, non-toxicity, 100% biodegradability and non-flammability in liquid form, so it is 100% eco-friendly and any accidental leaks are neither harmful or dangerous;
- **Closed-loop operation** means almost no need for refills, no steam nor water consumption and no emissions, so plants can be cheaper to operate, simpler and more compact than equivalent steam-based ones.

The fluid inside the plant undergoes several phase changes. Main process specifications are :

WORKING FLUID	
Type	Mixture of environment-friendly, non-toxic, non-flammable HFCs
Operational range (temperature/pressure)	60-165°C, max. 20 bar
Condensation temperature	~33°C
Turbine Input temperature /pressure	145 °C / 16,08 bar
Condenser output pressure	1,17 bar
Organic vapor mass flow	~ 6 kg/s (145/40°C)

TURBINE, GENERATOR AND INVERTER

These are the main technical specification of the ZE-500-LT module turbine, generator and inverter:

TURBINE	
Type	Single-stage radial inflow turbine w/fixed nozzles, directly coupled to the generator shaft
Operating Temperature (Input/Output)	145°C / ~ 100°C
Stage pressure	PS 16 (tested to 24 bar)
Materials	Machined steel (body) / Aluminium alloy (impeller)
Speed control	Feedback loop on the generator current output
Seals and gaskets	Sealed labyrinth on impeller back and optionally at generator interface. Environmental seal using gaskets and O-rings

GENERATOR	
Type	Synchronous, permanent magnet
Power Output	561 kWe
Rotational Speed	9500 Rpm (9...10 kRpm)
Output voltage	503- 577 VAC @ 500Hz
Cooling system	Water jacket, 15 KW _r heat dissipation
Cooling fluid	Water + glycol mix @ T _{in} <40°C, 30l/min flow
Additional cooling (optional)	Working fluid injection

INVERTER	
Type	2 x IGBT- mains synchronized modules
Total output power (nominal / max)	550 kWe / 700 kWe max (2x350 kW modules)
Output voltage /frequency	400 V + 5% Tol. @ 50 Hz +0,5% Tol.
Cooling	Water-cooled
Max operational environmental temperature	40°C
Braking chopper	Built-in, 200 kJ on external resistor bank

SYSTEM COMPONENTS

HEAT EXCHANGERS

The **hot-side heat exchangers** used in this power generation module are of the brazed plate type - the most compact and efficient solution for several applications. They are made by brazing several quality corrugated steel plates together, taking care first to turn the fishbone-shaped corrugations on each plate 180° from the adjacent plate. Keeping in mind that the fluid-passing sections are very small, the heat exchange-to-encumbrance ratio of these exchangers is great. Among the characteristics for this type of exchanger, these are the most important ones:

- **Small size** : they occupy up to 10% of the space other exchanger types require, making transport easier and the plant smaller.
- **Low temperature differentials**: they can work with minimal temperature differences between cooling fluid and cooled fluid, thus increasing overall system efficiency;
- **Low load losses**: in most cases, even lower than those of a coaxial exchanger.
- **Resistance to dirt and corrosion**: high fluid turbulence and total use of the available surface means a drastic reduction in deposits due to material contained in the fluids. What's more, they may be perfectly cleaned using normal detergent fluids. Corrosion problems are avoided by using specifically resistant materials in their construction.

The **cold-side exchangers** are instead of the time-tested **shell-and-tube type**, which besides having a lower cost than equivalent brazed plate components, has better performances and is easier to clean than brazed plate exchangers when dealing with potentially contaminated cooling water, a problem that hot-side components - working in a closed loop - do not have to face.

HEAT EXCHANGERS	
Type	Brazed plate (evaporators & preheaters) Shell & tube (regenerator and condenser)
Operating pressures	30 bar (Nominal) / 39 bar (Test) /225 bar (Burst)
Construction materials	AISI316 S/S & 99,9% copper (evaporator/preheater) Steel (regenerator/condenser)
Max working temperature	195°C

CONDENSATION TANK

Required to keep an adequate reserve of liquid working fluid for the plant, it is made of rustproofed carbon steel with PN25 connections, has a capacity of **500 litres** and is equipped with a **built-in level sensor**.

WORKING FLUID PUMP

Required to make the condensed working fluid flow back into the ORC loop, its motor is of the closed short-circuited cage type with external ventilation . **Energy-efficient** (class I), it has **IP55 protection** and is certified to the **EN 60034-1 standard**. Equipped with **class F insulation** (Tmax=155°C), its hydraulic part is kept in place between the upper cap and the pump body by tie rods.

CONTROL PANEL

The control panel, hosted in an off-skid cabinet, hosts all **control, supervision, automation and communication electronics** for the power generation module. Equipped with a **touch-screen local control panel** as well as a **remote control interface**, it contains all **process management electronics**, including **temperature and pressure control** electronics and **alarm management systems**. The control panel also include a built-in **cellular modem router** that allows password-protected, policy-regulated remote access and system control through the Internet..

INVERTER and POWER DUMP SYSTEM

Two off-skid cabinet hosts the **inverter circuitry** that conditions the generated power, modifying its phase, frequency and voltage to exacting requirements before sending it to the **mains interface panel** with low-voltage protection circuitry.

Two other off-skid cabinets host the **resistor banks** where each inverter **dumps and dissipates as heat** all the power generated as the turbine spins down during emergency stops, given that - due to safety considerations - in that situation the skid is totally cut off from the mains.

IN SHORT

Compact & efficient brazed plate evaporator and preheater heat exchangers

Sturdy shell-&-tube regenerator and condenser heat exchangers

Ample reservoir of working fluid

High-efficiency recirculation pumps

Fully automated control system

No human presence required

Touch-screen synoptic control panel

Remote control via mobile internet interface

Power dump system included

SKID DIMENSIONS

IN SHORT

Standard version mounted on 2 skids for indoor installation + separate control panels

Skid dimensions:
Hot side (main) skid
5.0 x 2.8 x h 3.2 m
Cold side skid:
5.2 x 3.3 x h 4.6 m

Dry Weights :
7 t (hot side)
11.5 t (cold side)
3 t (control panels)

Paneled version available

Containerized, weatherproof version for outdoor installation available

Custom skid designs available upon request

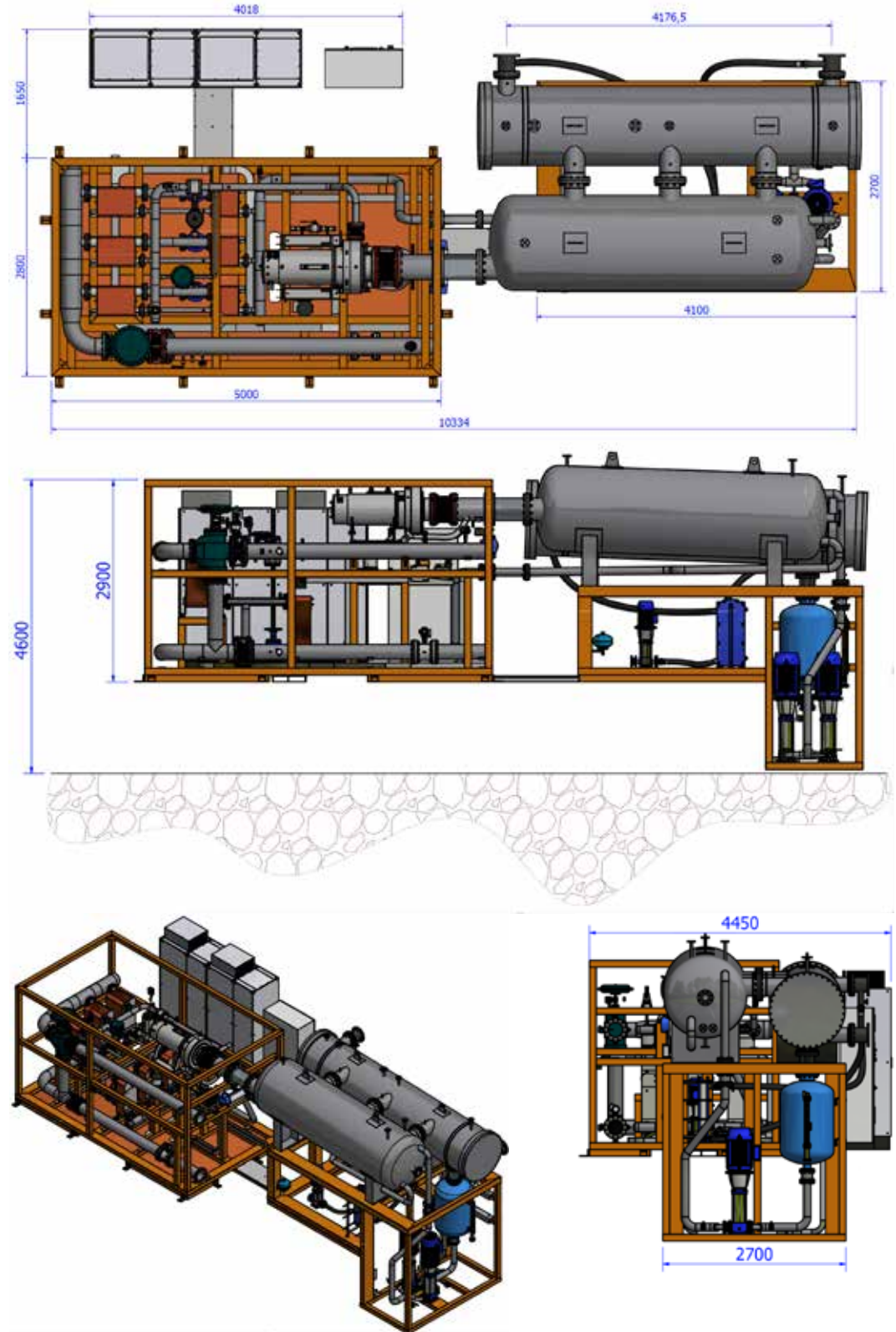

ALL OUR BEST EFFORTS HAVE BEEN MADE TO ENSURE THAT THE DATA CONTAINED IN THIS DOCUMENTS ARE CORRECT AND UP TO DATE.

NOTWITHSTANDING THAT, THEY ARE TO BE CONSIDERED PURELY INDICATIVE, NOT CONTRACTUALLY BINDING AND SUBJECT TO CHANGE WITHOUT NOTICE .

© 2018 ZUCCATO ENERGIA SRL
ALL RIGHTS RESERVED

DOCUMENT ID :
ZE SK ZE500LT 190607 EN

Please note that the skid also requires **at least 1.5 meters of free space on all sides** for easier maintenance access.

Zuccato Energia, being the system developer and manufacturer may also build the skid in non-standard dimensions different from the above, to tailor the system on the client's needs.