

Product Sheet

ORC System



ORC MODULE
ZE - 50 - ULH

PLANT TECHNOLOGY

The structure of the plant we proposed is based on the so-called Low-Temperature [Organic Rankine Cycle](#) (ULH-ORC), and can be summarized in the diagram in [Figure 1](#). A heat source [1] heats a special working fluid, placed inside a closed ORC circuit, through a [closed hot water circuit](#) and a primary exchanger, also called [evaporator](#) [2].

This organic fluid, completely biodegradable and non-toxic, boils in the evaporator at temperatures far lower than the boiling point of water, becoming a high-pressure gas whose expansion drives a specially built and sized [turbine](#) [3]. The high-speed rotation of the turbine shaft drives the rotor of

a generator [directly keyed](#) to it, producing electricity [4] that can be either self-consumed or fed into the grid after synchronizing phase, frequency, and voltage with the existing grid current via a power converter.

At the turbine outlet, the working fluid, still in gaseous form, is carried to a [condenser](#) [5], where it releases excess heat and returns to a liquid state, which is then collected in a tank.

The liquid is then ready to be pumped back into the primary heat exchanger, completing the closed circuit.

The excess heat released in the condenser represents a source of thermal energy that can also be directly used for other purposes: preheating or drying of biomass (thus reducing its moisture content and increasing its energy value), space heating, production of hot water for industrial production processes, etc. If this does not happen, the residual heat can be dissipated via a compact cooling tower or a [dry cooler](#) [6].

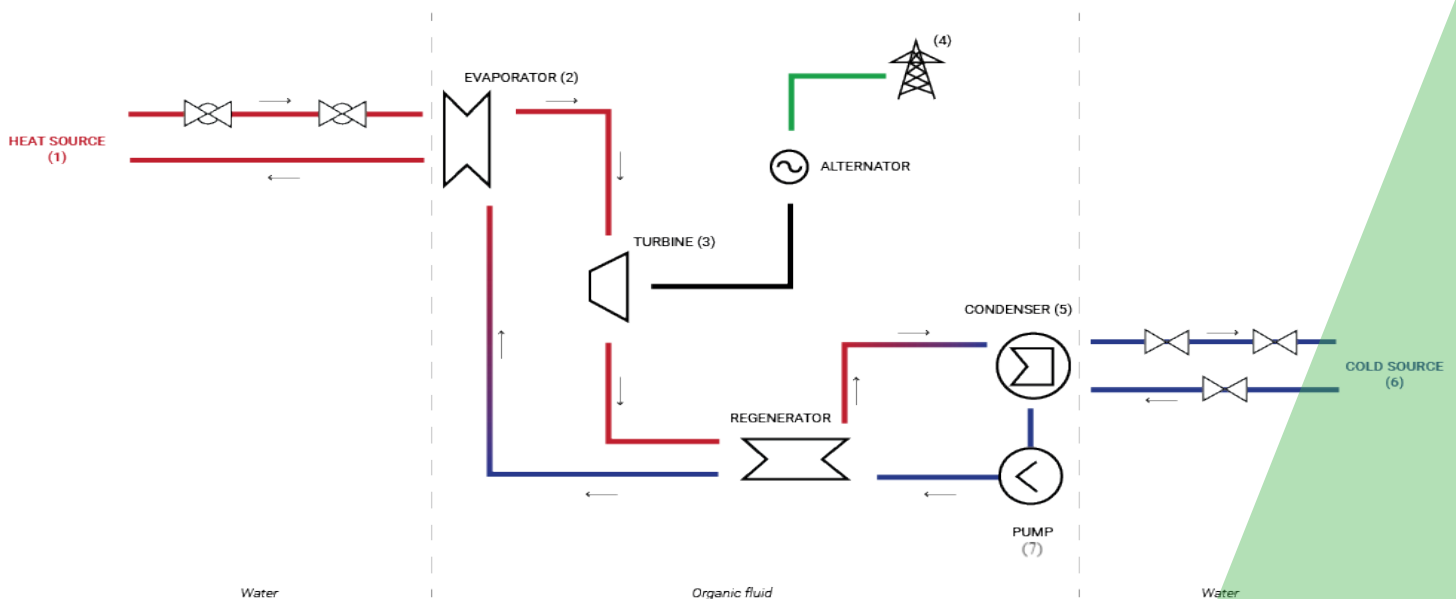

Figure 1 - How the ORC system works

INNOVATION

Designed and manufactured in-house using the most advanced technologies (finite element analysis and CFD fluid dynamics analysis), ZE turbogenerators are designed from the outset to operate within a low-temperature Organic Rankine Cycle (ORC), in which a specially selected working fluid provides higher efficiency and significant advantages compared to conventional steam turbines:

- **Low operating temperature** allows the use of even "poor" heat sources;
- **high condensing temperature** allows the use of economical air-cooled condensers;
- **completely dry working fluid**, which does not cause erosion of the turbine blades, increasing reliability and reducing inspections and maintenance costs;
- **low operating pressures** (< 20 bar) reduce risks, regulatory issues, and system costs;
- **no atmospheric discharge** (closed-cycle operation).

The working fluid used in the ORC circuit is ozone-friendly, non-toxic, and 100% biodegradable. The ZE series turbogenerators – specifically engineered from the ground up for installation in small-scale plants – incorporate targeted design solutions aimed at maximizing efficiency:

- **Direct turbine-alternator coupling**: no friction from the gearbox;
- **long-life ceramic bearings** allow for high rotation speeds;
- **inverters specifically designed and sized for each turbine size** to feed electricity into the grid with optimal conversion efficiency.

This **innovative technology** has been successfully tested in the numerous systems installed by Zuccato Energia worldwide, from small biomass power plants to vegetable oil generators, from syngas and biogas plants to hotel thermal power plants, thermoelectric power plants, and district heating systems.

CIRCUIT COMPONENTS

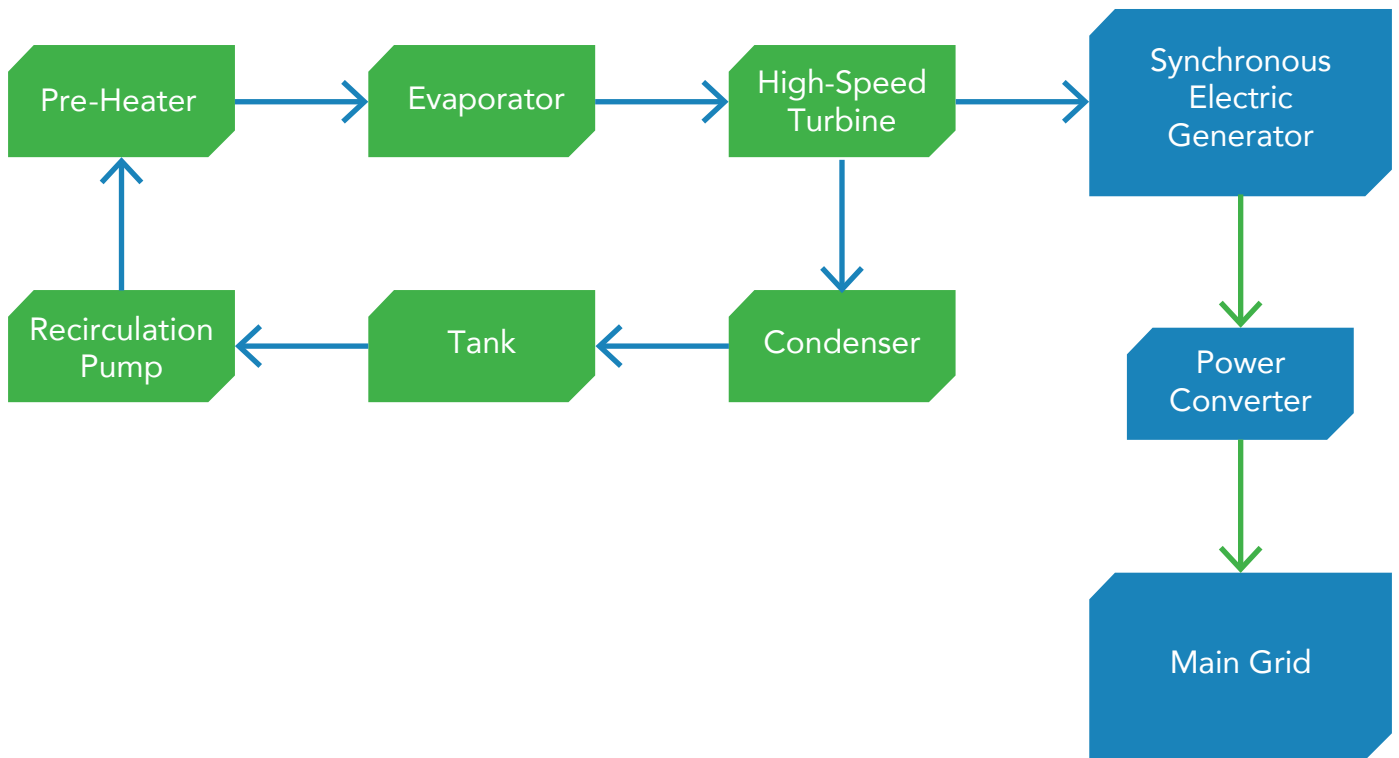

PROCESS DATA

WORKING FLUID	
Type	Eco-friendly, non-toxic, non-flammable hydrofluoroolefin
Working Temperature	60 - 165 °C
Condensation Temperature	~ 33°C
Working Pressure	max. 20 bar

HEAT EXCHANGER	
Type	Brazed plate
Max Pression	30 bar (Nominal) / 39 bar (Test)
Materials	AISI316 S/Steel & 99 % coppe
Max Working Temperature	195 °C

PREHEATER + EVAPORATOR

Total Thermal Power Input	550 kWt
Vector Fluid	Hot Water
Vector Fluid Temperature (input/output)	≥ 94 °C / 86 °C
Vector Fluid Flow Rate	16.42 kg/s
Power Output	50 kWe

CONDENSER

Thermal Dissipation Power	470 kWt
Condenser Cooling Water Temperature (in/out)	26 °C / 31 °C
Condensation water flow-rate	22.46 kg/s

TURBINE

Type	Single-stage radial inflow turbine w/fixed nozzles, directly coupled to the generator shaft
Operating Temperature (input/output)	85 °C in / ~ 60 °C out
Stage Pressure	PS 4.42 (tested to 10 bar)
Materials	Machined steel (body) / Aluminium alloy (impeller)
Speed Control	Feedback loop on the generator current output
Seals and Gaskets	Sealed labyrinth on impeller back and (optionally) at the generator interface Outward: statics, O-rings

GENERATOR

Type	Synchronous, permanent magnet
Power Output	50 kWe
Voltage and Frequency	503 - 577 VAC @ 500Hz
Rotational Speed	13.000 Rpm (12...18 kRpm)
Rectifier / Synchronizer	Built-in / Included
Cooling System	Water jacket
Cooling Fluid	Water + glycol mix, TIN<40 °C

INVERTER

Type	IGBT- mains synchronized
Power Output	50 kWe
Output Frequency	from 380 to 480 V 3-phase, 50/60Hz
Max Operational Environmental Temperature	40°C
Breaking Chopper	Built-in, 50 kW

ZE-50-ULH SKID DIMENSIONS

The system is supplied mounted on a compact frame (skid) that houses all the main components, with the exception of the cooling system, which is a separate system.

The following diagrams show the dimensions of the **standard skid, designed for indoor installation**, sheltered from the elements, or at least in a rain-protected area (e.g., a canopy).

A noise-reducing paneled version and a closed, containerized, weatherproof version are also available, making the skid suitable for outdoor installation.

Please note that the skid requires at least **1.5 meters of free space** all around for easy maintenance access.

As a designer and manufacturer, Kajiwara can also build custom skids with non-standard dimensions to suit the customer's needs.

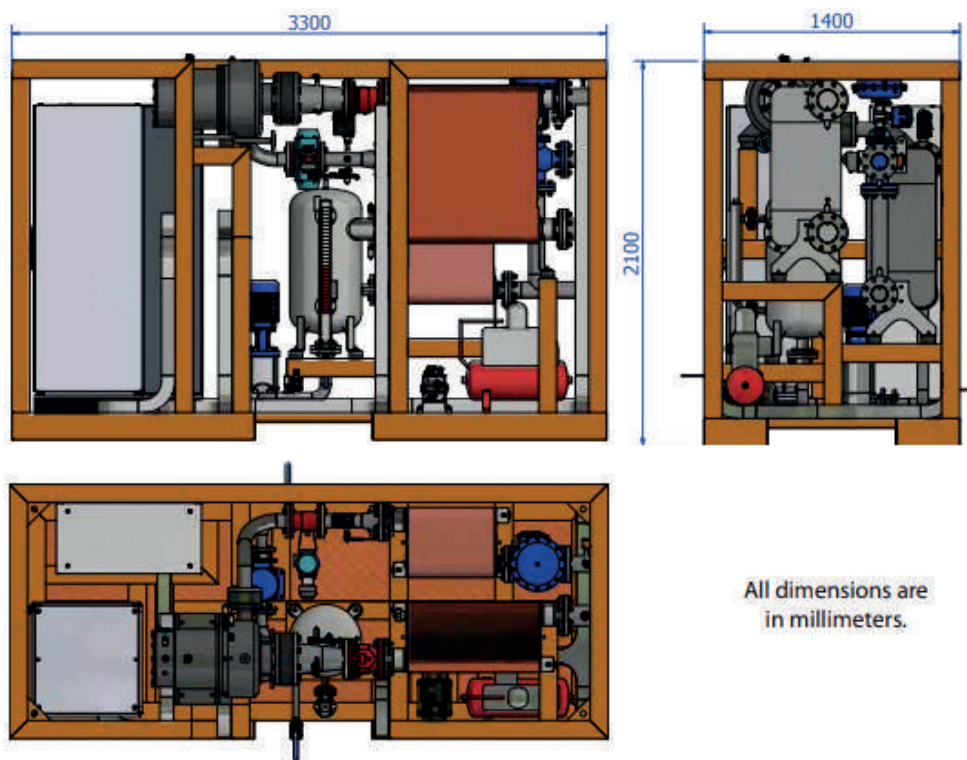

All dimensions are in millimeters.